

ROBOTICS

# Product manual

## Force Control Package



Trace back information:  
Workspace Main version a585  
Checked in 2024-05-20  
Skribenta version 5.5.019

**Product manual**  
**Force Control Package**

Document ID: 3HAC091307-001

Revision: A

The information in this manual is subject to change without notice and should not be construed as a commitment by ABB. ABB assumes no responsibility for any errors that may appear in this manual.

Except as may be expressly stated anywhere in this manual, nothing herein shall be construed as any kind of guarantee or warranty by ABB for losses, damage to persons or property, fitness for a specific purpose or the like.

In no event shall ABB be liable for incidental or consequential damages arising from use of this manual and products described herein.

This manual and parts thereof must not be reproduced or copied without ABB's written permission.

Keep for future reference.

Additional copies of this manual may be obtained from ABB.

Original instructions.

© Copyright 2024 ABB. All rights reserved.  
Specifications subject to change without notice.

# Table of contents

Overview of this manual .....	7
<b>1 Introduction</b>	<b>9</b>
1.1 Overview .....	9
1.2 Delivery .....	11
1.3 ABB force sensor .....	12
1.4 Adapter unit .....	19
1.4.1 Overview .....	19
1.4.2 Adapter unit type A .....	25
1.4.3 Adapter unit type B .....	26
1.4.4 Adapter unit type C .....	27
1.4.5 Adapter unit type D .....	28
1.4.6 Adapter unit type E .....	30
1.4.7 Adapter unit type F .....	32
1.4.8 Adapter unit type G .....	34
1.5 Cables .....	36
<b>2 Installation</b>	<b>39</b>
<b>3 Maintenance</b>	<b>45</b>
<b>4 Decommissioning</b>	<b>47</b>
4.1 Introduction to decommissioning .....	47
4.2 Environmental information .....	48
<b>5 Troubleshooting</b>	<b>49</b>
5.1 Sensor related .....	49
5.2 Robot related .....	51
<b>6 Spare parts</b>	<b>55</b>
<b>7 Reference information</b>	<b>57</b>
7.1 ATI Force sensor .....	57
7.2 Tightening torque .....	58
7.3 Unit conversion .....	60
<b>Index</b>	<b>61</b>

**This page is intentionally left blank**

# Overview of this manual

## About this manual

This manual contains information about the Force Control Package, which is used together with software RW Force Control options for robot systems running on an OmniCore controller.



### Note

It is the responsibility of the integrator to provide safety and user guides for the robot system.

## Usage

This manual should be used during installation and maintenance of the hardware components in the Force Control Package.



### Note

Before any work on or with the robot is performed, the safety information in the product manual for the controller and manipulator must be read.

## Who should read this manual?

This manual is intended for:

- installation personnel
- maintenance personnel

## Prerequisites

A maintenance/repair/installation craftsman working with an ABB Robot must:

- be trained by ABB and have the required knowledge of mechanical and electrical installation/repair/maintenance work.
- have the knowledge of RAPID programming with FlexPendant in RobotWare.

## References

Documentation referred to in the manual, is listed in the table below.

Reference	Document ID
<i>Operating manual - OmniCore</i>	3HAC065036-001
<i>Operating manual - Integrator's guide OmniCore</i>	3HAC065037-001
<i>Product manual - OmniCore C30</i>	3HAC060860-001
<i>Product manual - OmniCore C30 Type A</i>	3HAC089064-001
<i>Product manual - OmniCore C90XT</i>	3HAC073706-001
<i>Product manual - OmniCore V250XT Type B</i>	3HAC087112-001
<i>Product manual - OmniCore V400XT</i>	3HAC081697-001
<i>Operating manual - RobotStudio</i>	3HAC032104-001
<i>Technical reference manual - RAPID Overview</i>	3HAC065040-001

Continues on next page

## Overview of this manual

---

*Continued*

Reference	Document ID
<i>Technical reference manual - RAPID Instructions, Functions and Data types</i>	<i>3HAC065038-001</i>
<i>Technical reference manual - System parameters</i>	<i>3HAC065041-001</i>
<i>Application manual - Force control with software and hardware</i>	<i>3HAC070206-001</i>

---

## Revisions

Revision	Description
A	First edition.



# 1 Introduction

## 1.1 Overview

### About ABB Force Control

ABB Force Control products contains all the required hardware and software to run the robot in force control mode, in which, hardware contains both the hardware components in Force Control Package and floor cables.

Following illustration shows the hardware required for force control applications.

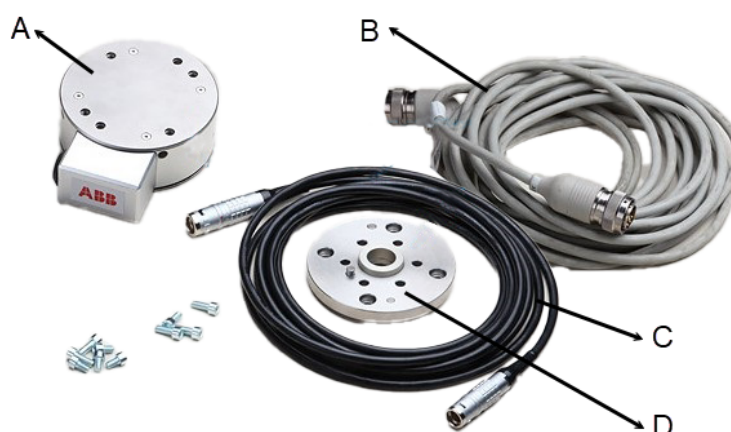

xx240000846

Item	Name	Description
A	ABB force sensor	Can be used to measure force and torque. For detailed information about ABB force sensor, see <a href="#">ABB force sensor on page 12</a> .
B	Floor cable	Control cable connecting the sensor cable to the controller cabinet. For detailed information about the floor cable, see <a href="#">Cables on page 36</a> .
C	Sensor cable	Cable connecting the force sensor to the floor cable. For detailed information about the sensor cable, see <a href="#">Cables on page 36</a> .
D	Adapter unit	Includes adapter plates(s), screws and pins that are used to mount the force sensor onto the robot wrist. For detailed information about the adapter unit, see <a href="#">Adapter unit on page 19</a> .

*Continues on next page*

# 1 Introduction

## 1.1 Overview

*Continued*

### Application example

ABB Force Control products are commonly used in robot machining application and robot assembly application. The following figure shows a hardware connection example in machining application.

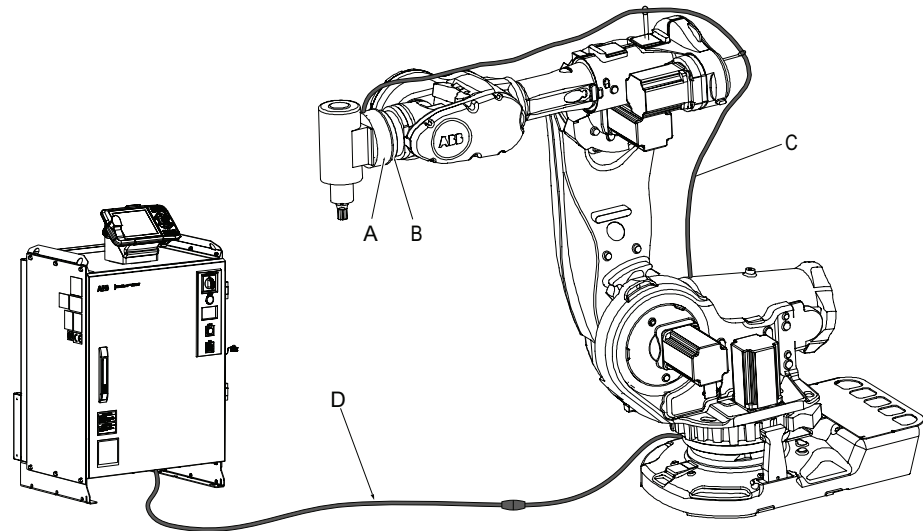

xx240000847

A	ABB force sensor
B	Adapter unit
C	Sensor cable
D	Floor cable

---

## 1.2 Delivery

---

### Hardware components

Please check if the delivered packages contain all the hardware components that ordered. Following components are delivered by default:

- ABB force sensor. For detailed information, see [ABB force sensor on page 12](#).
- Sensor cable. For detailed information, see [Cables on page 36](#).
- Adapter unit. For detailed information about the adapter unit, see [Adapter unit on page 19](#).
- Floor cable. For detailed information, see [Cables on page 36](#).

---

### Software options

The Force Control Package works with the following software option, which users can choose according to their application and demand:

- 3415-1 Force Control Standard



#### Note

The Force Control Package must be used together with ABB robots and OmniCore controllers.



#### Tip

ABB Force Control products have integrated the functions of machining application and assembly application. For information about how to use ABB Force Control products in machining and assembly applications, see *Application manual - Force control with software and hardware*.

# 1 Introduction

## 1.3 ABB force sensor

### 1.3 ABB force sensor

#### Specification

ABB force sensor is a 6 DOF force sensor that is fully integrated into the robot hardware and software. There are three models of ABB force sensor: small model, medium model and large model.

Force sensors follow the definitions defined in SAE J2570-2000. For detailed description of sensor specifications, refer to SAE J2570-2000. Contact ABB if any additional specification is required.

#### General

Specification type	Small force sensor	Medium force sensor	Large force sensor
DOF	6 DOF	6 DOF	6 DOF
Protection	IP65	IP65	IP65
Material	SS304	SS304	SS304
Weight	1.4 kg	1.41 kg	6 kg
Outside diameter x height (unit: mm)	104x40	104x40	168x62
Orientation	Aligned with tool coordination system of robot	Aligned with tool coordination system of robot	Aligned with tool coordination system of robot

#### Force and torque range

Specification type	Small force sensor	Medium force sensor	Large force sensor
Force measurement range	Fx/Fy: 165 N; Fz: 495 N	Fx/Fy: 660 N; Fz: 1980 N	Fx/Fy: 2500 N; Fz: 6250 N
Force measurement resolution	Fx/Fy: 0.03 N; Fz: 0.11 N	Fx/Fy: 0.09 N; Fz: 0.33 N	Fx/Fy: 0.33 N; Fz: 1.0 N
Torque measurement range	Mx/My/Mz: 15 Nm	Mx/My/Mz: 60 Nm	Mx/My/Mz: 400 Nm
Torque measurement resolution	Mx/My/Mz: 0.003 Nm	Mx/My/Mz: 0.008 Nm	Mx/My/Mz: 0.053 Nm
Uncertainty	Fx/Fy/Fz: 1.71% Mx/My: 1.9%; Mz: 2.1%	Fx/Fy/Fz: 1.8% Mx/My: 1.92%; Mz: 2.4%	Fx/Fy/Fz: 1.98% Mx/My: 2.1%; Mz: 2.1%

#### Environment condition

Specification type	Small force sensor	Medium force sensor	Large force sensor
Operating temperature (°C)	0 °C- 52°C	0 °C- 52°C	0 °C- 52°C
Storage temperature (°C)	-40°C - +70°C	-40°C - +70°C	-40°C - +70°C
Calibration temperature (°C)	20°C-25°C	20°C-25°C	20°C-25°C
Temperature compensation	Yes	Yes	Yes
Compensated temperature range (°C)	10 to 70	10 to 70	10 to 70

#### Performance

Specification type	Small force sensor	Medium force sensor	Large force sensor
Power supply (V)	24 V (15-30 V)	24 V (15-30 V)	24 V (15-30 V)
Current (mA) nominal (24V power)	140	140	140

*Continues on next page*

Specification type	Small force sensor	Medium force sensor	Large force sensor
Current (mA) peak (24V power)	200	200	200
Overload capacity (%F.S.)	1000	1000	1000
Lowest free air resonant frequency (HZ)	700	1200	1400
Non-linearity (%F.S.)	0.5	0.5	0.5
Hysteresis (%F.S.)	0.5	0.5	0.5
Crosstalk (%F.S.)	2.5	2.5	2.5
Zero offset (%F.S.)	10	10	10
Stiffness	F>3.0*E+7N/m; T>3.0*E+3Nm/rad	F>3.0*E+7N/m; T>3.0*E+3Nm/rad	F>6.0*E+7N/m; T>6.0*E+3Nm/rad
Resonance frequency	700	1200	1400
Output	EtherCAT	EtherCAT	EtherCAT
Overload protection <sup>i</sup>	10 times	10 times	10 times

<sup>i</sup> Overload capacity of the force sensor is not the same as typical capacity and could not be treated as the same definition. Overload capacity is designed for accidental usage scenarios when mishandling occurs. It is not recommended to use the overload range of the sensor; otherwise, lifetime of the force sensor will shorten as a consequence of misuse.



### Note

In most cases, torque applied to the force sensor will limit the force sensor capability, especially if tool with long leverage is used. TuneMaster can be used to monitor the force and torque values. For details about TuneMaster, see the section "TuneMaster" in *Application manual - Force control with software and hardware* and *Application manual - TuneMaster*.

To protect the force sensor, do not accelerate or decelerate the robot greatly in linear and rotation motions.

*Continues on next page*

# 1 Introduction

## 1.3 ABB force sensor

Continued

### Type mapping

Force sensor type	Robot type <sup>i</sup>	Adapter unit (qty.)	Adapter unit type	Adapter plate type	Sensor cable length	Floor cable length
Small force sensor	IRB 1100	Single	A	S1	5 m	3 m / 7 m / 15 m
	IRB 1200					
	IRB 1300		B	S2		
	IRB 1600					
	IRB 2400		C	S3	10 m	
	IRB 2600					
	IRB 4400L/10					
	IRB 4600 - 20/2.50					
Medium force sensor	IRB 2400	Double	D	M1 & M2	5 m	
	IRB 2600					
	IRB 4400L/10					
	IRB 4600-20/2.50					
	IRB 4400/60		E	M3 & M4	10 m	
	IRB 4600-40/2.55					
	IRB 4600-45/2.05					
	IRB 4600-60/2.05					
IRB 5710-90/2.3 LID	F	L1 & L2				
IRB 5710-70/2.7 LID						
IRB 4400/60			G	L3 & L4		
IRB 4600-40/2.55						
IRB 4600-45/2.05						
IRB 4600-60/2.05						
Large force sensor	IRB 4400/60	Double	E	M3 & M4	10 m	
	IRB 4600-40/2.55					
	IRB 4600-45/2.05					
	IRB 4600-60/2.05					
	IRB 5710		F	L1 & L2		
	IRB 5720					
	IRB 6710					
	IRB 6650S					
IRB 6660						
IRB 6700/6720/6730/6740						
IRB 6700/6720/6730/6740						

<sup>i</sup> Unless otherwise specified, all the variants of the listed robots supports the corresponding force sensor.



#### Note

ABB force sensor can be substituted by ATI Axia series Force/Torque sensors in ABB force control applications. Contact your local ATI support for the proper model in Axia series that is applicable to your robot and force control application.

See <https://www.ati-ia.com/> for more information.

For detailed information about how to configure ATI force sensor, see *Application manual - Force control Standard*.

Continues on next page

### Dimension

#### Small force sensor

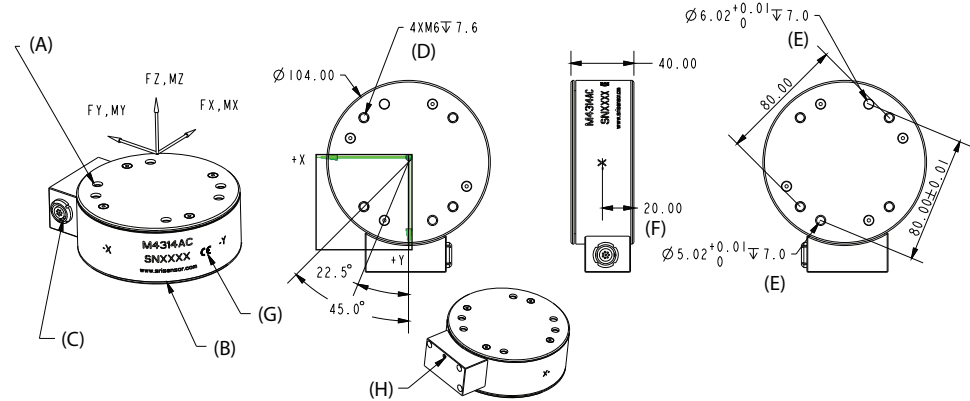

xx240000701

A	Mounting tool to this side
B	Mounting robot arm to this side
C	LEMO connector EEG.IT.308.CLL MAPPING connector FGG.IT.308.CYCC60Z
D	90° equal space on $\Phi 80.00$ BC, both sides
E	On $\Phi 80.00$ BC, both sides
F	Neutral axis
G	CE mark
H	LED

Continues on next page

# 1 Introduction

## 1.3 ABB force sensor

Continued

### Medium force sensor

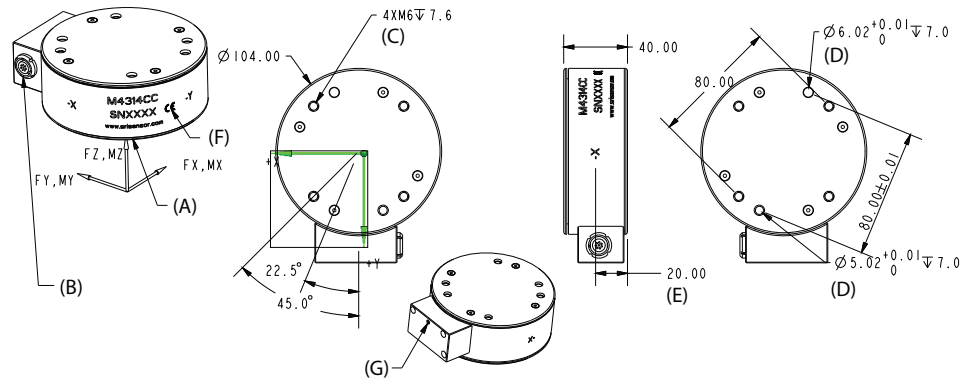

xx2400000702

A	Mounting robot arm to this side
B	LEMO connector EEG.IT.308.CLL MAIING connector FGG.IT.308.CYCC60Z
C	90° equal space on $\Phi 80.00$ BC, both sides
D	On $\Phi 80.00$ BC, both sides
E	Neutral axis
F	CE mark
G	LED

Continues on next page



### Large force sensor

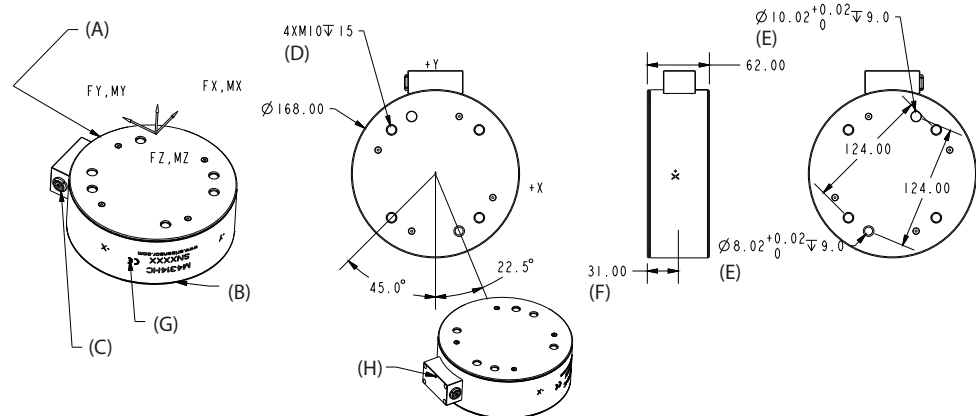

xx240000703

A	Mounting tool to this side
B	Mounting robot arm to this side
C	LEMO connector EEG.IT.308.CLL MAIING connector FGG.IT.308.CYCC60Z
D	90° equal space on $\Phi 124.00$ BC, both side
E	On $\Phi 124.00$ BC, both side
F	Neutral axis
G	CE mark
H	LED

### Sensor connector



xx240000898

Pin	Description	Pin	Description
1	+24V+	5	RDP
2	GND	6	RDN
3	TDP	7	RX
4	TDN	8	TX

Continues on next page

# 1 Introduction

## 1.3 ABB force sensor

*Continued*

### LED light

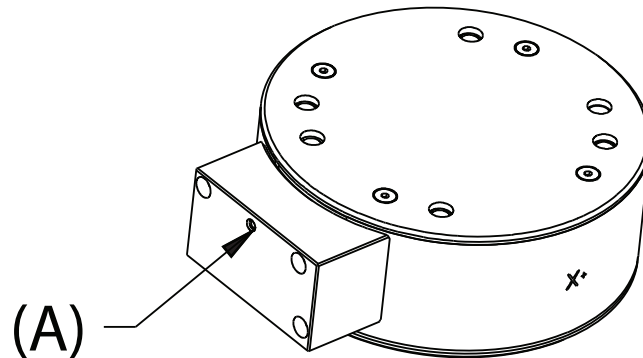

xx2400000910

A	LED
LED status	Sensor status
Off	Power off
Flashing	Work properly
On (solid)	Abnormal

### CE Conformity

This device complies with EMC Directive 2004/108/EC.



#### CAUTION

The contact force affects the robot path. For example, something is blocking the path or the work piece is outside of the predefined work range of the robot, the robot may deviate the intended path and may cause unexpected damage.

## 1.4 Adapter unit

### 1.4.1 Overview

#### Overview introduction

There are seven types of adapter unit which contains following components by standard:

- Adapter plate to mount the force sensor on the robot flange. Adapter plates are classified into 7 adapter units based on the plate types and quantity. There are 11 adapter plate types, 3 of which are used alone and 8 of which are used in pair.

For detailed information about what types of and how many adapter plates are needed for each robot type, see [Type mapping on page 14](#).

- Mounting screws. Used to mount the sensor to the robot by adapter plates and mount the cable bracket on the adapter plate of the sensor.
- Positioning pins. Used for easy and accurate positioning during the installation.

#### Adapter flange dimension

The force sensor should be mounted on the tool flange of robot axis by ABB specific adapter plate. Detailed flange dimensions are listed below.

#### Adapter plate S1

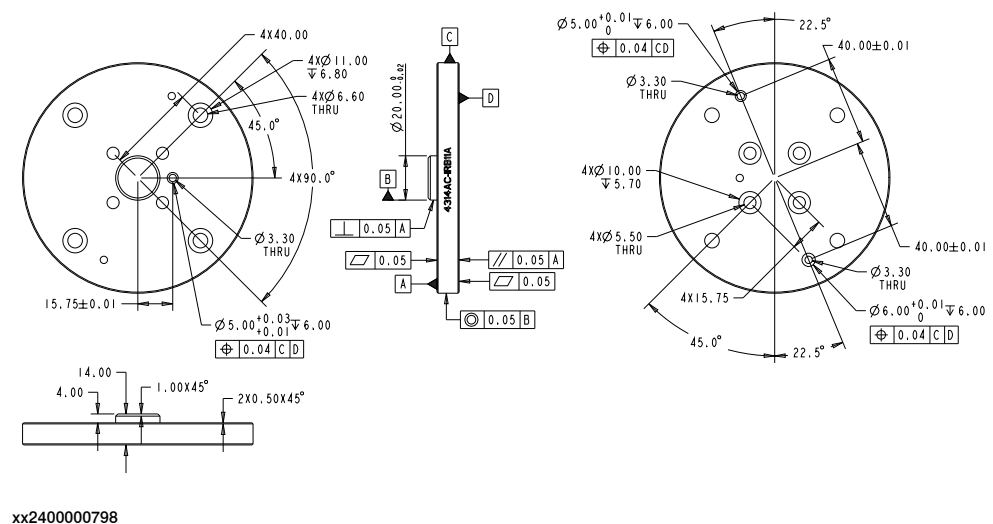

Continues on next page

# 1 Introduction

## 1.4.1 Overview

*Continued*

### Adapter plate S2

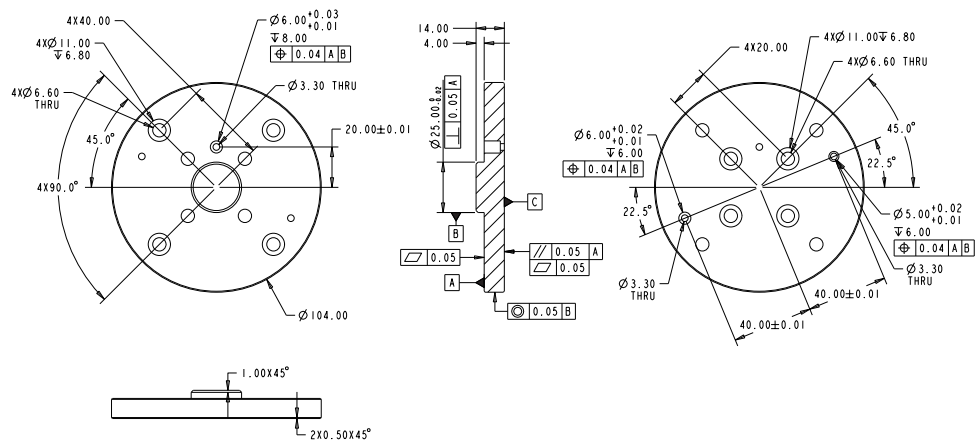

xx240000799

### Adapter plate S3

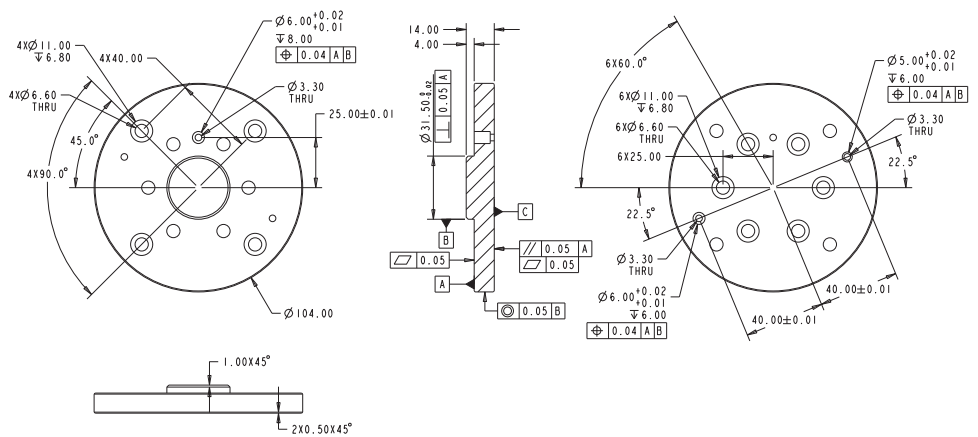

xx240000800

*Continues on next page*

### Adapter plates M1 and M2

Adapter plates M1 and M2 are used in pair. Adapter plate M1 is mounted to the robot tool flange, and plate M2 is mounted between plate M1 and force sensor. Following figure shows the dimension of adapter plate M1.

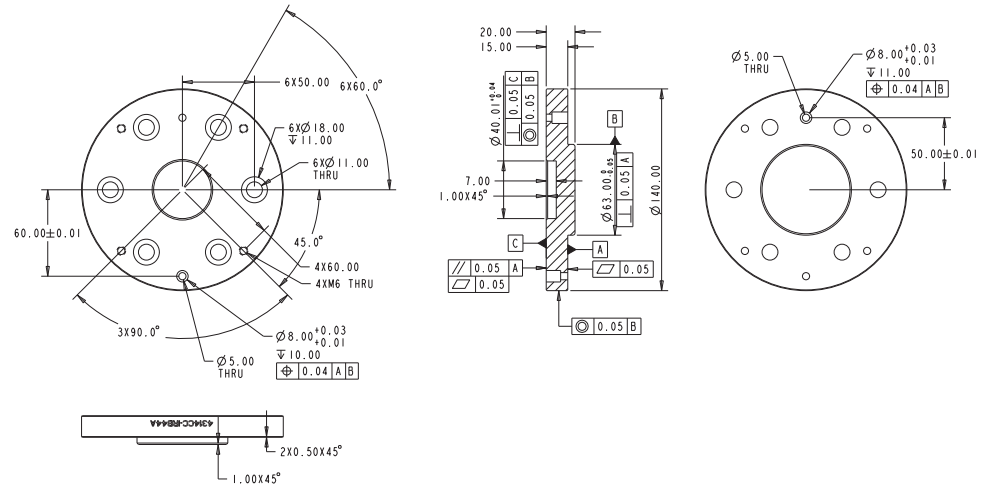

xx240000801

Following figure shows the dimension of adapter plate M2.

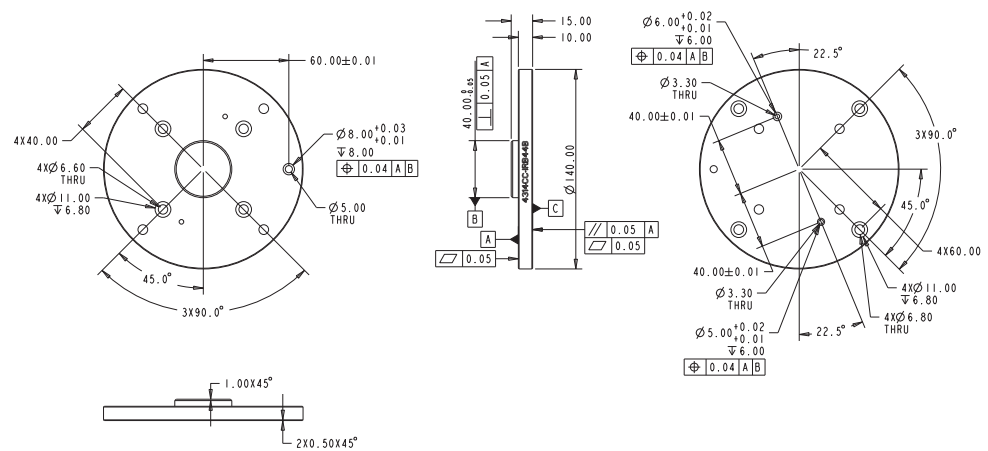

xx240000802

Continues on next page

# 1 Introduction

## 1.4.1 Overview

Continued

### Adapter plates M3 and M4

Adapter plates M3 and M4 are used in pair. Plate M3 is mounted to the robot tool flange, and plate M4 is mounted between plate M3 and force sensor.

Following figure shows the dimension of adapter plate M3.

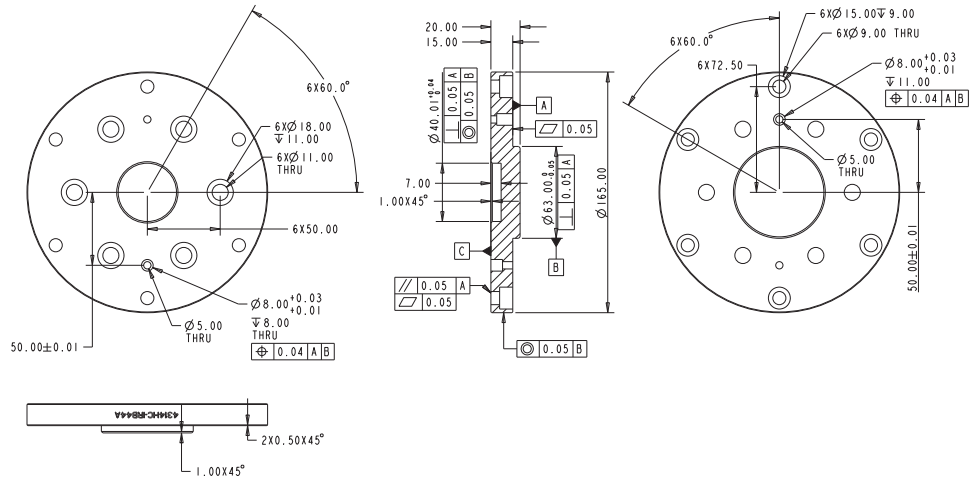

xx240000803

Following figure shows the dimension of adapter plate M4.

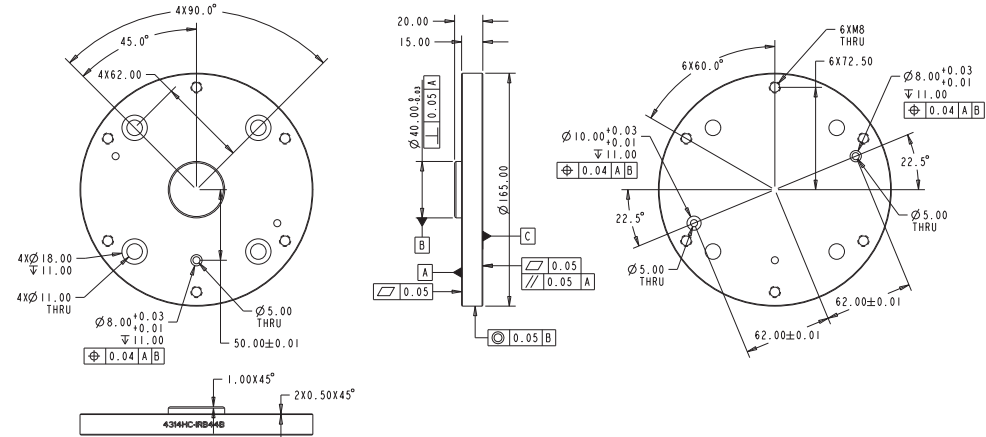

xx240000804

Continues on next page

### Adapter plates L1 and L2

Adapter plates L1 and L2 are used in pair. Plate L1 is mounted to the robot tool flange, and plate L2 is mounted between plate L1 and force sensor.

Following figure shows the dimension of adapter plate L1.

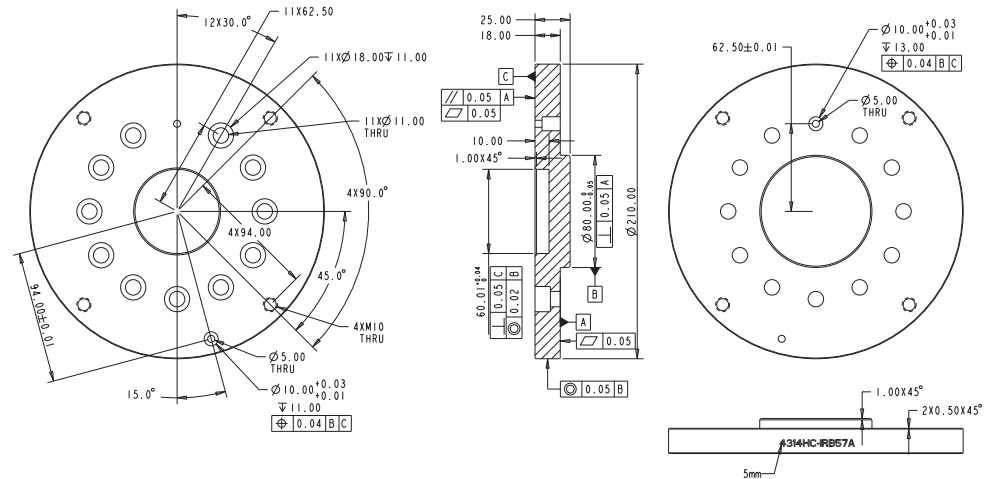

xx240000805

Following figure shows the dimension of adapter plate L2.

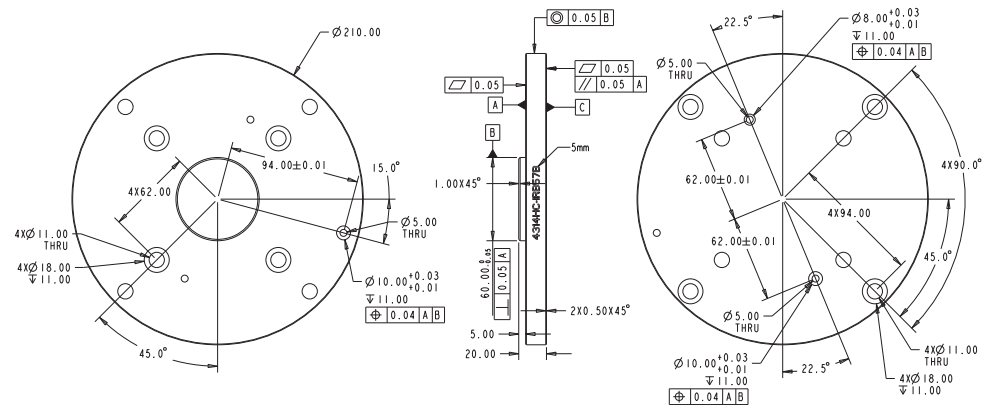

xx240000806

Continues on next page

# 1 Introduction

## 1.4.1 Overview

Continued

### Adapter plates L3 and L4

Adapter plates L3 and L4 are used in pair. Plate L3 is mounted to the robot tool flange, and plate L4 is mounted between plate L3 and force sensor.

Following figure shows the dimension of adapter plate L3.

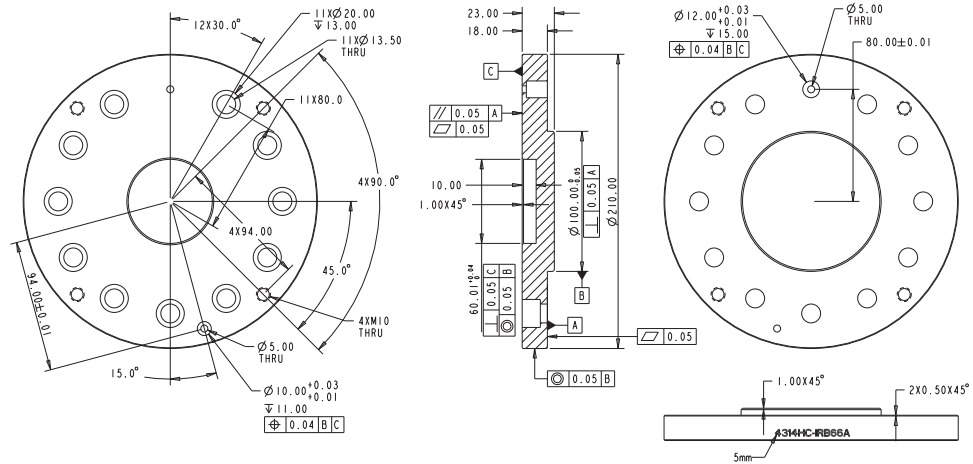

xx2400000807

Following figure shows the dimension of adapter plate L4.

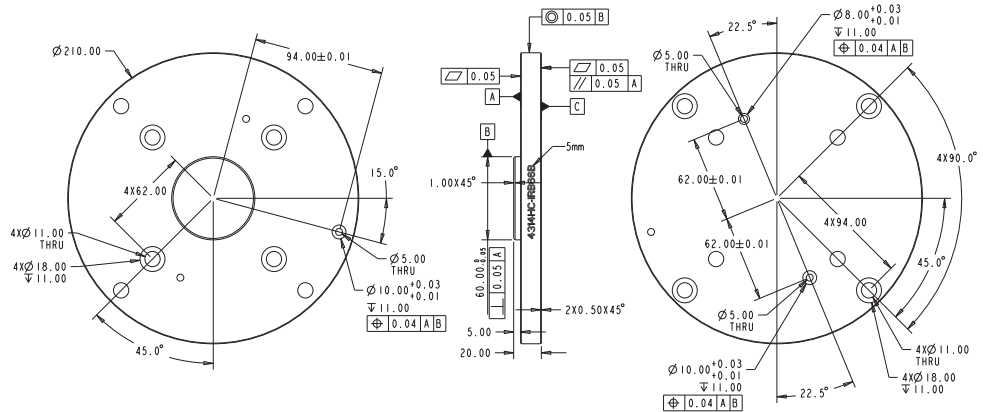

xx2400000807



1.4.2 Adapter unit type A

Component

Component of adapter unit type A are listed in the following table. For detailed adapter plate dimension information, see [Adapter flange dimension on page 19](#).

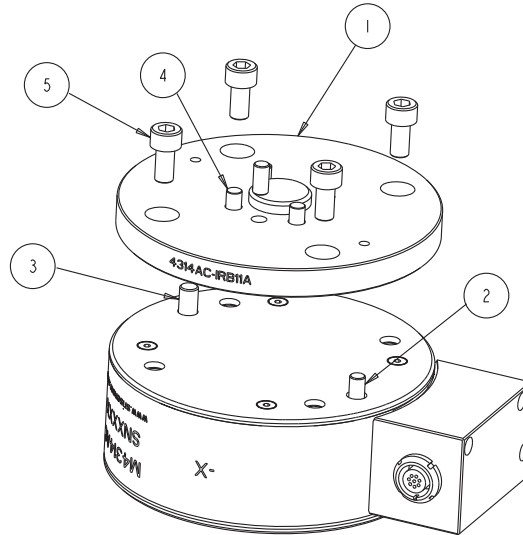

xx240000859

No.	Name	Specifica- tion/Mod- el	Reference no.	Quant- ity(Unit:piece)	Description/Note
1	Adapt plate	S1	3HAC090710-001	1	Mounted to the robot tool flange.
2	Positioning pin	Φ5x10	3HAC090872-001	2	One is to position the adapter plate to the robot tool flange; the other is to position the adapter plate to the force sensor.
3	Positioning pin	Φ6x12	3HAC090873-001	1	To position the adapter plate to the force sensor.
4	Hexagon socket head cap screws	M5x10	3HAC090863-001	4	To fix the adapter plate to the robot tool flange.
5	Hexagon socket head cap screws	M6x12	3HAC090864-001	4	To fix the adapter plate to the force sensor.

# 1 Introduction

## 1.4.3 Adapter unit type B

### 1.4.3 Adapter unit type B

#### Component

Component of adapter unit type B are listed in the following table. For detailed adapter plate dimension information, see [Adapter flange dimension on page 19](#).

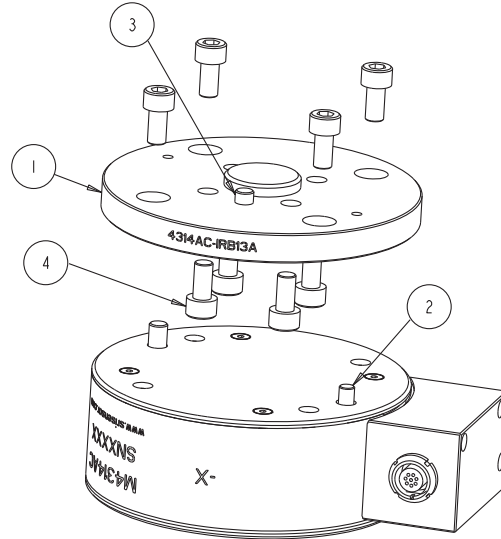

xx2400000860

No.	Name	Specification/Model	Reference no.	Quantity(Unit:piece)	Description/Note
1	Adapt plate	S2	3HAC090712-001	1	Mounted to the robot tool flange.
2	Positioning pin	Φ5x10	3HAC090872-001	1	To position the adapter plate to the force sensor.
3	Positioning pin	Φ6x12	3HAC090873-001	2	One is to position the adapter plate to the robot tool flange; the other is to position adapter plate to the force sensor.
4	Hexagon socket head cap screws	M6x12	3HAC090864-001	8	Four are to fix the adapter plate to the robot tool flange; the others are to fix the adapter plate to the force sensor.

## 1.4.4 Adapter unit type C

## Component

Component of adapter unit type C are listed in the following table. For detailed adapter plate dimension information, see [Adapter flange dimension on page 19](#).

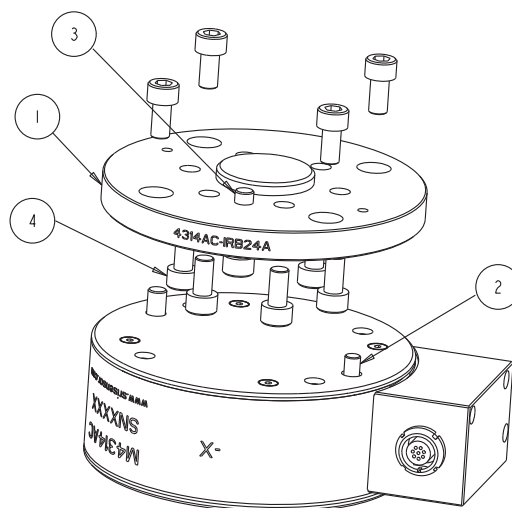

xx240000861

No.	Name	Specification/Model	Reference no.	Quantity(Unit:piece)	Description/Note
1	Adapt plate	S3	3HAC090713-001	1	Mounted to the robot tool flange.
2	Positioning pin	Φ5x10	3HAC090872-001	1	To position the adapter plate to the force sensor.
3	Positioning pin	Φ6x12	3HAC090873-001	2	One is to position the adapter plate to the robot tool flange; the other is to position the adapter plate to the force sensor.
4	Hexagon socket head cap screws	M6x12	3HAC090864-001	10	Six are to fix the adapter plate to the robot tool flange; the others are to fix the adapter plate to the force sensor.

# 1 Introduction

## 1.4.5 Adapter unit type D

### 1.4.5 Adapter unit type D

#### Component

Component of adapter unit type D are listed in the following table. For detailed adapter plate dimension information, see [Adapter flange dimension on page 19](#).

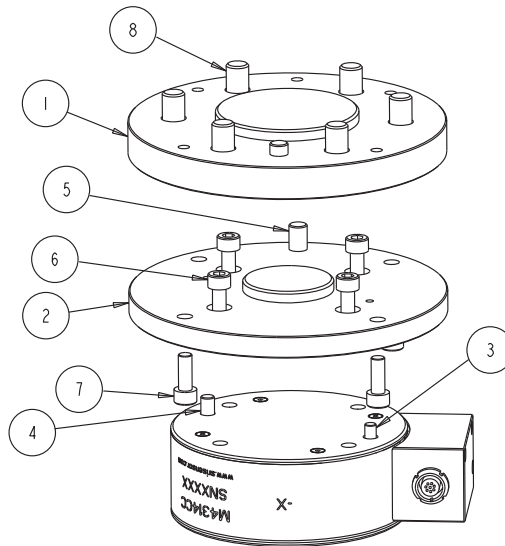

xx240000862

No.	Name	Specifica- tion/Mod- el	Reference no.	Quant- ity(Unit:piece)	Description/Note
1	Adapt plate	M1	3HAC090714-001	1	Mounted to the robot tool flange.
2	Adapt plate	M2	3HAC090715-001	1	Mounted between adapter plate M1 and force sensor.
3	Positioning pin	Φ5x10	3HAC090872-001	1	To position adapter plate M2 to the force sensor.
4	Positioning pin	Φ6x12	3HAC090873-001	1	To position adapter plate M2 to the force sensor.
5	Positioning pin	Φ8x16	3HAC090874-001	2	One is to position adapter plate M1 to the robot tool flange; the other is to position adapter plate M2 to adapter plate M1.
6	Hexagon socket head cap screws	M6x12	3HAC090864-001	4	To fix adapter plate M2 to the force sensor.
7	Hexagon socket head cap screws	M6x16	3HAC090866-001	4	To fix adapter plate M2 to adapter plate M1.

Continues on next page

No.	Name	Specification/Model	Reference no.	Quantity(Unit:piece)	Description/Note
8	Hexagon socket head cap screws	M10x16	3HAC090870-001	6	To fix adapter plate M1 to the robot tool flange.

# 1 Introduction

## 1.4.6 Adapter unit type E

### 1.4.6 Adapter unit type E

#### Component

Component of adapter unit type E are listed in the following table. For detailed adapter plate dimension information, see [Adapter flange dimension on page 19](#).

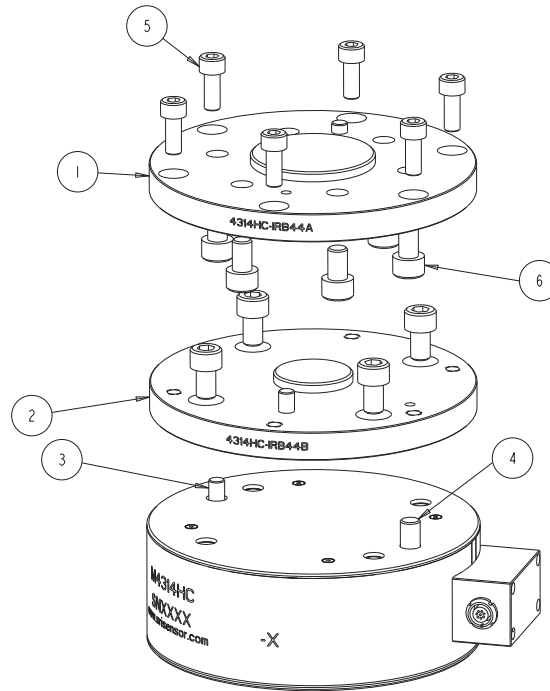

xx240000863

No.	Name	Specific- a- tion/Mod- el	Reference no.	Quant- ity(Unit:piece)	Description/Note
1	Adapt plate	M3	3HAC090716-001	2	Mounted to the robot tool flange.
2	Adapt plate	M4	3HAC090717-001	1	Mounted between adapter plate M3 and force sensor.
3	Positioning pin	Φ8x16	3HAC090874-001	3	One is to position adapter plate M3 to the robot tool flange; another is to position adapter plate M4 to adapter plate M3; and the third is to position adapter plate M4 to the force sensor.
4	Positioning pin	Φ10x20	3HAC090875-001	1	To position adapter plate M4 to the force sensor.
5	Hexagon socket head cap screws	M8x20	3HAC090867-001	6	To fix adapter plate M3 to adapter plate M4.

Continues on next page

No.	Name	Specific- a- tion/Mod- el	Reference no.	Quant- ity(Unit:piece)	Description/Note
6	Hexagon socket head cap screws	M10x16	3HAC090868- 001	10	Six are to fix adapter plate M3 to the robot tool flange; the others are to fix adapter plate M4 to the force sensor.

# 1 Introduction

## 1.4.7 Adapter unit type F

### 1.4.7 Adapter unit type F

#### Component

Component of adapter unit type F are listed in the following table. For detailed adapter plate dimension information, see [Adapter flange dimension on page 19](#).

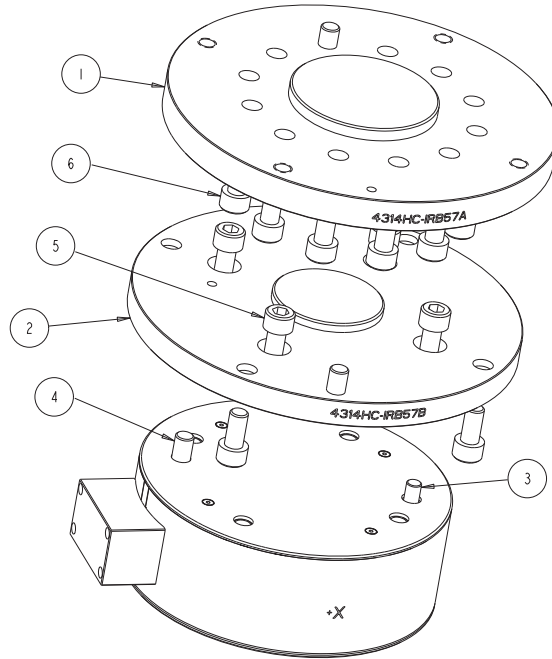

xx240000864

No.	Name	Specific- a- tion/Mod- el	Reference no.	Quant- ity(Unit:piece)	Description/Note
1	Adapt plate	L1	3HAC090718-001	2	Mounted to the robot tool flange.
2	Adapt plate	L2	3HAC090719-001	1	Mounted between adapter plate L1 and force sensor.
3	Positioning pin	Φ8x16	3HAC090874-001	1	To position adapter plate L2 to the force sensor.
4	Positioning pin	Φ10x20	3HAC090875-001	3	One is to position adapter plate L1 to the robot tool flange; another is to position adapter plate L2 to adapter plate L1; and the third is to position adapter plate L2 to the force sensor.
5	Hexagon socket head cap screws	M10x16	3HAC090868-001	4	To fix adapter plate L2 to the force sensor.

Continues on next page



No.	Name	Specific- a- tion/Mod- el	Reference no.	Quant- ity(Unit:piece)	Description/Note
6	Hexagon socket head cap screws	M10x20	3HAC090870- 001	15	Eleven are to fix adapter plate L1 to the robot tool flange; the others are to fix adapter plate L2 to adapter plate L1.

# 1 Introduction

## 1.4.8 Adapter unit type G

### 1.4.8 Adapter unit type G

#### Component

Component of adapter unit type G are listed in the following table. For detailed adapter plate dimension information, see [Adapter flange dimension on page 19](#).

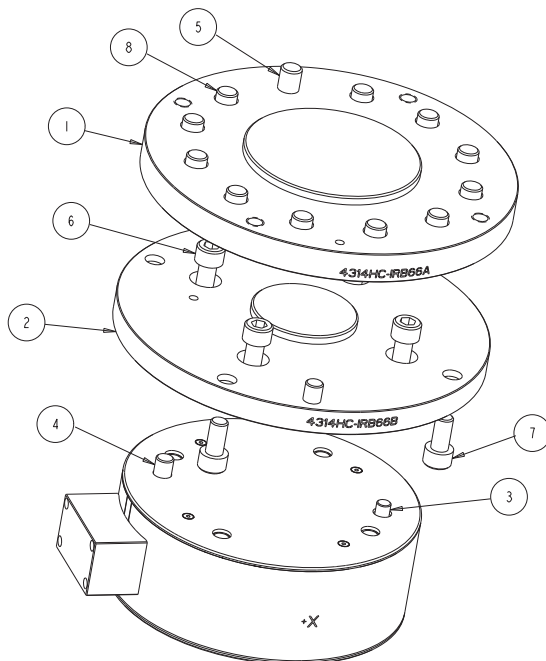

xx240000865

No.	Name	Specification/Model	Reference no.	Quantity(Unit:piece)	Description/Note
1	Adapt plate	L3	3HAC090720-001	2	Mounted to the robot tool flange.
2	Adapt plate	L4	3HAC090721-001	1	Mounted between adapter plate L3 and force sensor.
3	Positioning pin	Φ8x16	3HAC090874-001	1	To position adapter plate L4 to the force sensor.
4	Positioning pin	Φ10x20	3HAC090875-001	2	One is to position adapter plate L4 to adapter plate L3; the other is to position adapter plate L4 to the force sensor.
5	Positioning pin	Φ12x20	3HAC090876-001	1	To position adapter plate L3 to the robot tool flange.
6	Hexagon socket head cap screws	M10x16	3HAC090868-001	4	To fix adapter plate L4 to the force sensor.
7	Hexagon socket head cap screws	M10x20	3HAC090870-001	4	To fix adapter plate L4 to adapter L3.

Continues on next page

No.	Name	Specification/Model	Reference no.	Quantity(Unit:piece)	Description/Note
8	Hexagon socket head cap screws	M12x20	3HAC090871-001	11	To fix adapter plate L3 to the robot tool flange.

# 1 Introduction

## 1.5 Cables

### 1.5 Cables

#### Overview

The cables are high flexible, well shielded and should be grounded.

#### Wiring - sensor cable

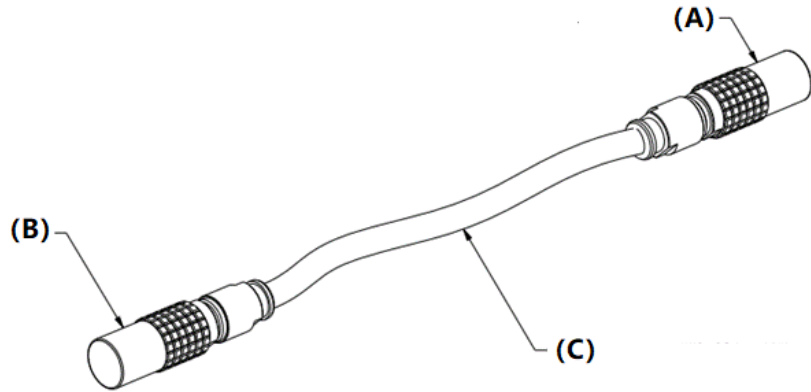

xx240000899

A	PHG.IB.308.CLLD62Z, connector to sensor
B	PHG.IB.308.CLLD62Z, connector to floor cable
C	Ethercat cable CAT.5e

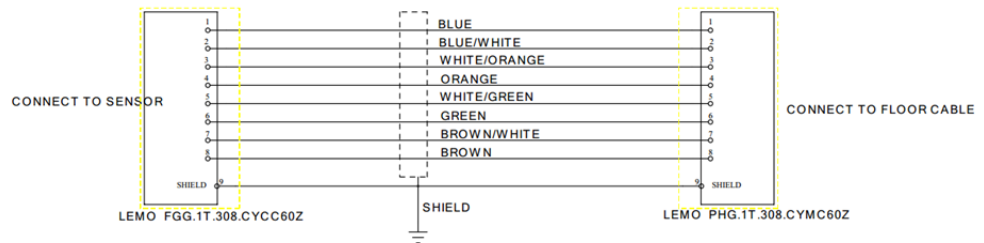

xx240000900

Continues on next page

### Wiring - floor cable

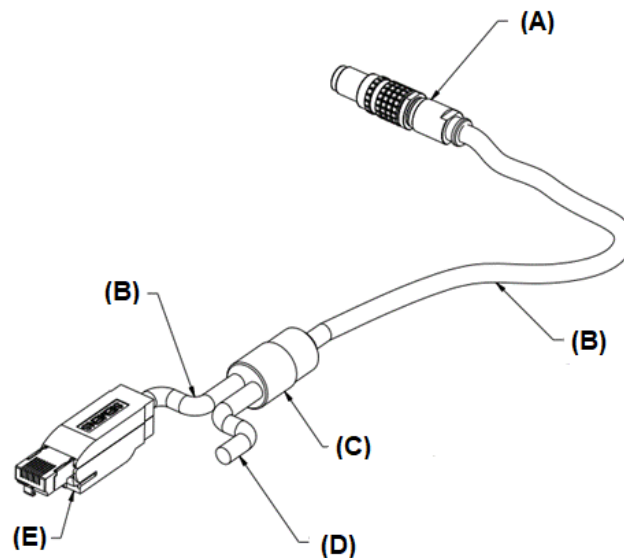

xx240000901

A	FGG.IT.308.CLAC65Z
B	Ethercat cable CAT.5e
C	Split adaptor
D	Power cable, free end
E	Ethercat connector, RJ45

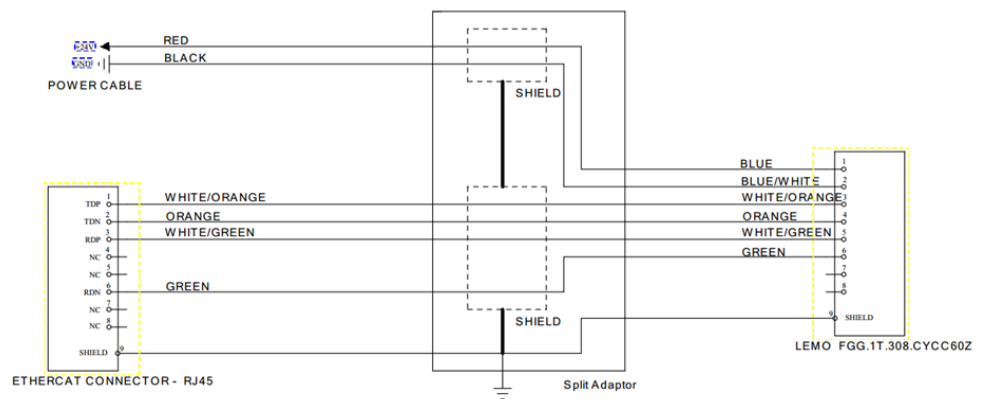

xx240000902

### Cable specification

Item	Description
Sensor cable length	5 m, 10 m <sup>i</sup>
Floor cable length	3 m, 7 m, 15 m <sup>i</sup>
Sensor cable lifetime	3 million times of bending

<sup>i</sup> See [Type mapping on page 14](#) for the robot type and sensor type that each cable length is applicable to.

**This page is intentionally left blank**

## 2 Installation

### Hardware installation

#### Tools

This table lists tools to be used when mounting the force sensor on the robot.

No.	Description	Small force sensor	Medium force sensor	Large force sensor	Quantity
1	M5 screw driver	X			1
2	M6 screw driver	X	X		1
3	M8 screw driver			X	1
4	M10 Screw driver		X	X	1
5	M12 Screw driver			X	1
6	M5 torque wrench	X			1
7	M6 torque wrench	X	X		1
8	M8 torque wrench			X	1
9	M10 Torque wrench		X	X	1
10	M12 Torque wrench			X	1
11	Rubber hammer	X	X	X	1

The following table lists the tightening torque of screws.

Dimension	Tightening torque (Nm)	Class
M5	10	12.9
M6	16	12.9
M8	40	12.9
M10	79	12.9
M12	130	12.9

#### Installation procedure

Use the following procedure to install a force sensor to a robot, in which the IRB 6700 with a large ABB force sensor is used as an example.



#### Note



Installation procedures of other force sensor types differ slightly because the screws and positioning pins used for mounting vary according to the adapter unit types and robot types. Refer to [Adapter unit on page 19](#) for the specification and quantity of screws and positioning pins that are applicable to your application.

	Description	Illustration/Note
1	Jog the robot to the home position.	

*Continues on next page*

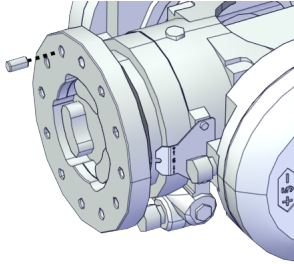
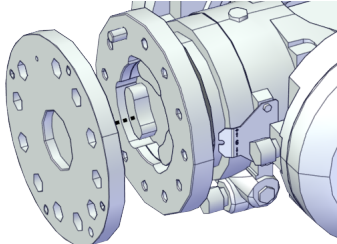
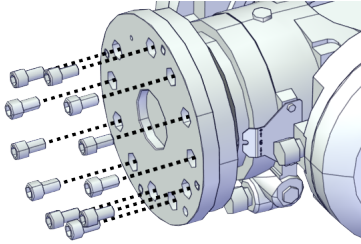

## 2 Installation

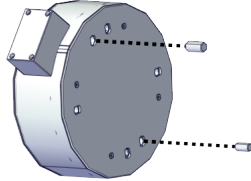
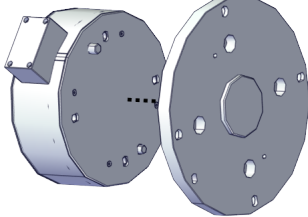
Continued

	Description	Illustration/Note
2	Insert a $\Phi 12 \times 20$ positioning pin in the positioning hole of the robot tool flange.	 <p data-bbox="1032 577 1145 600">xx240000849</p>
3	Mount adapter plate L3 on the robot tool flange with positioning pin aligned to the positioning hole of the adapter plate.	 <p data-bbox="1032 902 1145 925">xx240000850</p>
4	Fix adapter plate L3 to the robot tool flange with eleven M12x20 fixing screws.	 <p data-bbox="1032 1225 1145 1247">xx240000851</p>
5	Insert a $\Phi 10 \times 20$ positioning pin and a $\Phi 8 \times 16$ positioning pin in the positioning holes on the robot arm side of the force sensor.   <b>Note</b>  Do not mix the two sides of the force sensor. Refer to the force sensor drawings in <a href="#">Dimension on page 15</a> for the sensor sides.	 <p data-bbox="1032 1547 1145 1570">xx240000852</p>
6	Mount adapter plate L4 on the robot arm side of the force sensor with positioning pins aligned to the corresponding positioning holes of the adapter plate.	 <p data-bbox="1032 1874 1145 1897">xx240000853</p>

Continues on next page

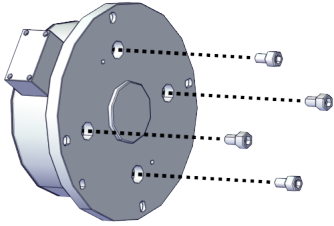
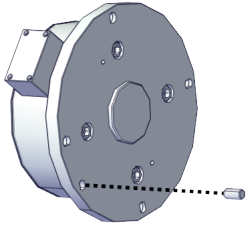

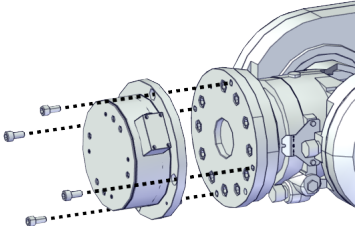
	Description	Illustration/Note
7	Fix adapter plate L4 to the force sensor with four M10x16 fixing screws.	 <p data-bbox="1066 577 1174 600">xx240000854</p>
8	Insert a $\Phi 10 \times 20$ positioning pin in the positioning hole on adapter plate L4.	 <p data-bbox="1066 900 1174 922">xx240000855</p>
9	<p data-bbox="529 958 1056 1039">Mount the force sensor to the robot by aligning adapter plate L4 to adapter plate L3 and securing with four M10x20 fixing screws.</p> <div data-bbox="533 1057 676 1115">  <p data-bbox="619 1070 676 1102"><b>Note</b></p> </div> <p data-bbox="529 1128 1056 1263">When mounting adapter plates M1/M2, L1/L2 and L3/L4, the fixing screws must be mounted from the force sensor side. For other adapter plates, the fixing screws are mounted from the robot side.</p>	 <p data-bbox="1066 1223 1174 1245">xx240000856</p>
10	Connect the sensor cable between the force sensor and floor cable.	
11	Connect the floor cable to the controller.	

Continues on next page

## 2 Installation

Continued



### Note

The procedure to fix the ABB force sensor in the room is the same as that to fix ABB force sensor to the robot except that the adapter plate is not needed. The following figure illustrate a mounting example of room fixed sensor.

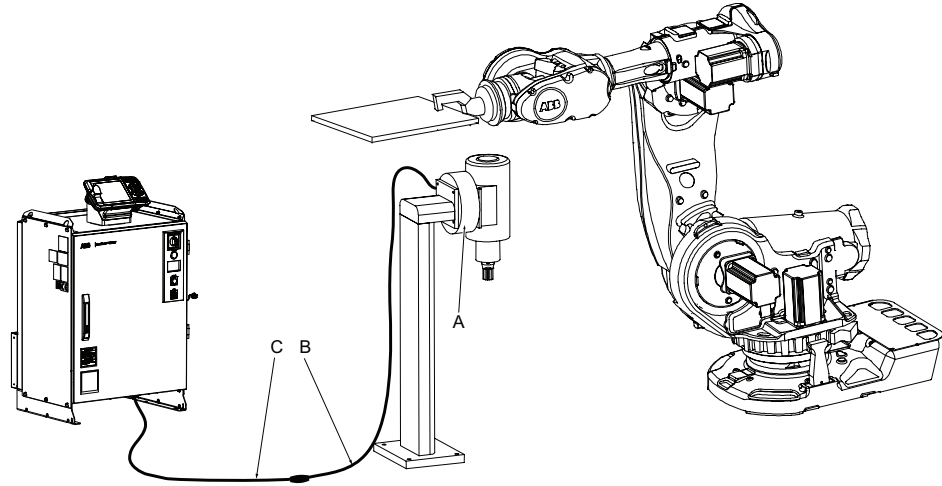

xx2400000857

### Software installation

	Description	Illustration/Note
1	Connect a PC with RobotStudio and RobotWare to the robot controller.	See <i>Operating manual - RobotStudio</i> .
2	Modify the system in RobotStudio. Force Control parameters are set in the configuration topic <i>Motion</i> .	
3	Right click the <i>Configuration</i> node in RobotStudio, select <b>Load Parameters</b> and then <b>Load parameters and replace duplicates</b> .	See <i>Application manual - Force control with software and hardware</i> .
4	Now that the system is configured the last step is to program the application. To get started more easily there are some basic code examples on how to use Force control. There is also a RAPID component overview for easy usage.	



### Note

Force sensor calibration is required prior to any operation with force control enabled.

Continues on next page



### Note

Software RW Force Control options of ABB Force Control Package has been installed and configured in robot system when delivered. While users may still need to create their own system, install the software and do configuration themselves under circumstances as system corruption etc..

---

### Configuration

After the installation, configuration should be done in RobotStudio to start the application.

Base configuration for the Force Control Package is in **Controller > Configuration -> Motion**. Extra configuration also should be done according to the specific application.

For more information on how to configure a Force Control system, see *Application manual - Force control Standard*.

**This page is intentionally left blank**

## 3 Maintenance

---

### Periodic inspection

The following items should be periodically inspected for possible damages or wear.

- Cables

Weekly checking these items is recommended.

The following items should be periodically checked or cleaned to keep free of excessive dust, debris or moisture.

- Force sensor

Weekly checking these items is recommended.

---

### Periodic calibration

The force sensor should be periodically calibrated following ISO-9000 standard.

Annually calibration is recommended especially for applications that frequently cycle the loads applied to the transducer.

Please contact ABB when calibration is needed.

**This page is intentionally left blank**

# 4 Decommissioning

## 4.1 Introduction to decommissioning

### Introduction

This section contains information to consider when taking a product, robot or controller, out of operation.

It deals with how to handle potentially dangerous components and potentially hazardous materials.



#### Note

The decommissioning process shall be preceded by a risk assessment.

### Disposal of materials used in the robot

All used grease/oils and dead batteries **must** be disposed of in accordance with the current legislation of the country in which the robot and the control unit are installed.

If the robot or the control unit is partially or completely disposed of, the various parts **must** be grouped together according to their nature (which is all iron together and all plastic together), and disposed of accordingly. These parts **must** also be disposed of in accordance with the current legislation of the country in which the robot and control unit are installed.

See also [Environmental information on page 48](#).

### Transportation

Prepare the robot or parts before transport, this to avoid hazards.

## 4 Decommissioning

---

### 4.2 Environmental information

## 4.2 Environmental information

---

### Introduction

ABB robots contain components in different materials. During decommissioning, all materials should be dismantled, recycled, or reused responsibly, according to the relevant laws and industrial standards. Robots or parts that can be reused or upcycled helps to reduce the usage of natural resources.

### Symbol

The following symbol indicates that the product must not be disposed of as common garbage. Handle each product according to local regulations for the respective content (see table below).

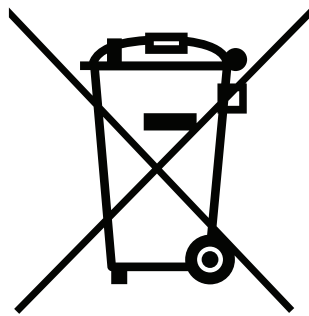

xx1800000058

### Materials used in the product

The table specifies some of the materials in the product and their respective use throughout the product.

Dispose components properly according to local regulations to prevent health or environmental hazards.

Material	Example application
Copper	Cables
Plastic/rubber	Cables, connectors, etc.



---

## 5 Troubleshooting

### 5.1 Sensor related

---

#### Force and torque reading saturation

##### Description

When the data from the force sensor reaches the positive or negative maximums, the gage in the force sensor is saturated.

##### Possible cause

Saturation occurs when:

- The sensor is loaded beyond its rated work range
- Electrical failure within the system

##### Solution

- Gradually reduce the load little by little.
  - Check if there is electrical failure within the system.
- 

#### Signal not accurate

##### Possible cause

- Zero offset too big
- Force sensor is not accurate

##### Solution

For too big zero offset, execute the following steps:

- 1 Move robot to zero position and make sure nothing is attached on the tool side of the sensor.

For not accurate force sensor, execute the following steps:

- 1 Attach a adapter on the sensor. Measure the weight with FCLoadID and record it as m1.
  - 2 Attach a load on the sensor. Measure the total weight again with FCLoadID and record it as m2.
  - 3 Measure the load on a balance and record it as m3.
  - 4 Compare m3 with m2-m1. If the result is larger than 1.5%FS, sensor is not accurate.
- 

#### Sensor signal not stable

##### Description

Signal is not stable in TuneMaster output.

##### Possible cause

- Loose connector connection
  - Damaged cable
  - Loose sensor attachment
  - Disturbance of surrounding equipment
- 

*Continues on next page*

## 5 Troubleshooting

---

### 5.1 Sensor related

*Continued*

- Sensor failure

#### Solution

- Check and confirm connections and cables are undamaged and firmly connected.
- Check electromagnetic interference of surrounding equipment
- Check if the sensor fails.

---

### Noise

#### Possible cause

Excessive noise can be caused by:

- Mechanical vibrations, possibly from a poor ground.
- Electrical disturbances
- Component failure within the system.

#### Solution

- Check if the ground is horizontal and smooth.
- Check if there is electrical disturbance.
- Check if component failure exists in the system.



#### Tip

Errors in force and torque reading could result from the bad data from the force sensor. Bad force/torque reading error could result in problems with threshold monitoring and sensor accuracy. Usually viewing the strain gage data of the force sensor can help to make the problem more clear.

---

## 5.2 Robot related

---

### Slow reaction

#### Description

The robot acts very slowly.

- Robot presses hard on the work piece.
- Robot leaves the work piece.

#### Possible cause

- FCLoadID is not done.
- Robot is not near working position when calibrated.
- Sensor calibration data is wrong.
- System parameters are not correctly defined. For example, damping is too large, lowest measured contact force is too high, bandwidth of the force loop filter is too low etc.

#### Solution

- Execute the instruction `FCLoadId`. See *Application manual - Force control with software and hardware*.
- Recalibrate the robot.
- Recalibrate the force sensor or import the correct calibration data.
- Modify system parameters until proper system parameters are got.

---

### Wrong reaction

#### Description

The robot moves to the wrong direction when it is being under certain force/torque.

#### Possible cause

- Damaged cable
- Wrong direction of sensor attachment
- Loose sensor or tool attachment
- Sensor failure
- Wrong calibration data

#### Solution

- Check if the cable is damaged.
- Check if the sensor is mounted with the right direction.
- Check if the sensor or the tool is firmly fixed.
- Check if the correct calibration data is imported.
- Replace a new sensor.

*Continues on next page*

## 5 Troubleshooting

---

### 5.2 Robot related

*Continued*

---

#### Drifting

##### Description

After a load is removed or applied, the force gage in the force sensor does not stabilize, but continues to increase or decrease. This may be observed more easily when viewing resolved force/torque data.

##### Possible cause

- Sensor is fixed tightly.
- Temperature change
- Mechanical coupling. Mechanical coupling is caused when a physical connection is made between the tool plate and the sensor body. Some mechanical coupling is common, as hoses and wires are attached to a tool.
- Internal failure of the sensor
- FCLoadID is not done.
- Robot is not near working position when calibrated.
- Sensor calibration data is wrong.
- The orientation of gravity is not with respect to the base frame.
- FC system parameters are not correctly defined. e.g. Damping is too low, lowest measured contact force is too low, bandwidth of force loop filter is too high etc.

##### Solution

- Keep the temperature in a stable level
  - Check if there is physical connection between the tool and the adapter, or between the adapter and the force sensor.
  - Check if hoses and wires are attached to the tool.
  - Check if the sensor is malfunctioned.
- 

#### Stop

##### Description

Robot stop during force control movement.

##### Possible cause

Generally, check the error message and follow the recommended actions.

- The sensor cable loose or broken will trigger emergency stop when Force Sensor Cable Check is enabled.
- TCP speed is higher than Max Press TCP Speed.
- Robot moves more than the supervision distance.
- Robot moves near singularity position.

##### Solution

- Check if the sensor cable is loose or broke.
- Check if the TCP speed is higher than Max Press TCP Speed.
- Check if the robot moves near singularity position.
- Check if the target is outside the work range of the robot.

*Continues on next page*

- Check if the sensor is malfunctioned.
- 

### No reaction

#### Description

The force sensor does not move under external force when force control is activated.

#### Possible cause

- Loose connector connection
- Broken cable
- Sensor failure
- Wrong calibration data

#### Solution

- Check if the cable is loose or broke.
- Check if the correct calibration data is imported.
- Check if the sensor is malfunctioned.

**This page is intentionally left blank**

## 6 Spare parts

### Spare part list

Following are the spare parts for ABB Force Control Package.

Item	ABB Reference no.	Description
1	3HAC090877-001	Small ABB force sensor
2	3HAC090878-001	Medium ABB force sensor
3	3HAC090879-001	Large ABB force sensor
4	3HAC090857-001	Sensor cable 5m
5	3HAC090890-001	Sensor cable 10m
6	3HAC090858-001	Control cable signal 3m
7	3HAC090859-001	Control cable signal 7m
8	3HAC090860-001	Control cable signal 15m

**This page is intentionally left blank**



## 7 Reference information

### 7.1 ATI Force sensor

---

#### About ATI force sensor

The ATI Axia series Force/Torque sensors are compatible alternative to ABB force sensors. Contact your local ATI support for the proper model in Axia series that is applicable to your robot and force control application.

See <https://www.ati-ia.com/> for more information.

## 7 Reference information

### 7.2 Tightening torque

### 7.2 Tightening torque

#### Tightening torque

Before tightening any screw, note the following:

- Determine whether a **standard** tightening torque or **special** torque is to be applied. The **standard torques** are specified in the following tables. Any **special torques** are specified in the repair, maintenance or installation procedure descriptions. **Any special torque specified overrides the standard torque!**
- Use the *correct tightening torque* for each type of screw joint.
- Only use *correctly calibrated* torque keys.
- *Always tighten the joint by hand*, and never use pneumatic tools.
- Use the *correct tightening technique*, that is *do not* jerk. Tighten the screw in a slow, flowing motion.
- Maximum allowed total deviation from the specified value is **10%!**

#### Oil-lubricated screws with slotted or cross-recess head screws

The following table specifies the recommended standard tightening torque for *oil-lubricated screws with slotted or cross-recess head screws*.

Dimension	Tightening torque (Nm) Class 4.8, oil-lubricated
M2.5	0.25
M3	0.5
M4	1.2
M5	2.5
M6	5.0

#### Oil-lubricated screws with allen head screws

The following table specifies the recommended standard tightening torque for *oil-lubricated screws with allen head screws*.

Dimension	Tightening torque (Nm) Class 8.8, oil-lubricated	Tightening torque (Nm) Class 10.9, oil-lubricated	Tightening torque (Nm) Class 12.9, oil-lubricated
M5	6	-	-
M6	10	-	-
M8	24	34	40
M10	47	67	80
M12	82	115	140
M16	200	290	340
M20	400	560	670
M24	680	960	1,150

*Continues on next page*

## Lubricated screws (Molycote, Gleitmo or equivalent) with allen head screws

The following table specifies the recommended standard tightening torque for *screws lubricated with Molycote 1000, Gleitmo 603 or equivalent with allen head screws.*

Dimension	Tightening torque (Nm) Class 10.9, lubricated <sup>i</sup>	Tightening torque (Nm) Class 12.9, lubricated <sup>i</sup>
M8	28	35
M10	55	70
M12	96	120
M16	235	280
M20	460	550
M24	790	950

<sup>i</sup> Lubricated with Molycote 1000, Gleitmo 603 or equivalent

## Water and air connectors

The following table specifies the recommended standard tightening torque for *water and air connectors* when *one or both* connectors are made of *brass*.

Dimension	Tightening torque Nm - Nominal	Tightening torque Nm - Min.	Tightening torque Nm - Max.
1/8	12	8	15
1/4	15	10	20
3/8	20	15	25
1/2	40	30	50
3/4	70	55	90

## 7 Reference information

---

### 7.3 Unit conversion

### 7.3 Unit conversion

---

#### Converter table

Use the following table to convert units used in this manual.

Quantity	Units		
Length	1 m	3.28 ft.	39.37 in
Weight	1 kg	2.21 lb.	
Weight	1 g	0.035 ounces	
Pressure	1 bar	100 kPa	14.5 psi
Force	1 N	0.225 lbf	
Moment	1 Nm	0.738 lbf-ft	
Volume	1 L	0.264 US gal	

# Index

## A

Accurate, 49

## C

Calibration, 45

Control

  cable, 55

copper

  disposal, 48

## D

Decommissioning, 47

Drifting, 52

## E

environmental information, 48

## H

hazardous material, 48

## L

Large, 55

## M

Medium, 55

## N

Noise, 50

No reaction, 53

## P

plastic

  disposal, 48

## R

Reaction, 51

reading

  saturation, 49

recycling, 48

rubber

  disposal, 48

## S

Sensor

  cable, 55

shipping, 47

Small, 55

Stable

  Loose, 49

Stop, 52

## T

transportation, 47

## U

upcycling, 48







**ABB AB**

**Robotics & Discrete Automation**

S-721 68 VÄSTERÅS, Sweden

Telephone +46 10-732 50 00

**ABB AS**

**Robotics & Discrete Automation**

Nordlysvegen 7, N-4340 BRYNE, Norway

Box 265, N-4349 BRYNE, Norway

Telephone: +47 22 87 2000

**ABB Engineering (Shanghai) Ltd.**

Robotics & Discrete Automation

No. 4528 Kangxin Highway

PuDong New District

SHANGHAI 201319, China

Telephone: +86 21 6105 6666

**ABB Inc.**

**Robotics & Discrete Automation**

1250 Brown Road

Auburn Hills, MI 48326

USA

Telephone: +1 248 391 9000

**[abb.com/robotics](http://abb.com/robotics)**